



Aircraft Industries



www.let.cz / pps@let.cz / +420 572 817 664
Aircraft Industries, a.s. / Na Záhonech 1177 / Kunovice 686 04 / Czech Republic

SERVICE LETTER

SL No. **L-410/015**

Aeroplane Type: **L-410**

Model(s): **All except
L 410 NG**

Date of Issue: **Feb 28, 2024**

Reason: Eliminating the possibility of damage to the ailerons and elevator during parking due to strong wind.

Description: Use of new blocking elements type for ailerons and elevator.

This service letter is issued to inform L-410 the airplane operators about the possibility of using a new type of blocking elements to lock the ailerons and elevator during an airplane parking.

The new type of blocking elements is intended for operators, who park their airplane permanently outside the hangar or park their airplane in location where strong wind can be expected.

Aircraft Industries, a.s. has developed the following new type of blocking elements, which can be used for ailerons and elevator.

Name / description	Type/ (Drawing No.)	Quantity	Pictures
The new blockade set is optional equipment			
Inside Aileron Blocking Elements	B922145L	1LH	<p style="text-align: center;">B922145L</p> <p style="text-align: center;">FLIGHT DIRECTION</p>



	B922145P	1RH	<p>B922145P</p> <p>FLIGHT DIRECTION</p>
Outside Aileron Blocking Elements	B922120L	1LH	<p>B922120L</p> <p>FLIGHT DIRECTION</p>
	B922120P	1RH	<p>B922120P</p> <p>FLIGHT DIRECTION</p>
Outer Elevator Blocking Elements	B922100L	1LH	<p>B922100L</p> <p>FLIGHT DIRECTION</p>
	B922100P	1RH	<p>B922100P</p> <p>FLIGHT DIRECTION</p>

Note: The older type of ailerons and elevator blocking elements (B922150N) are still usable.

Installation Diagram

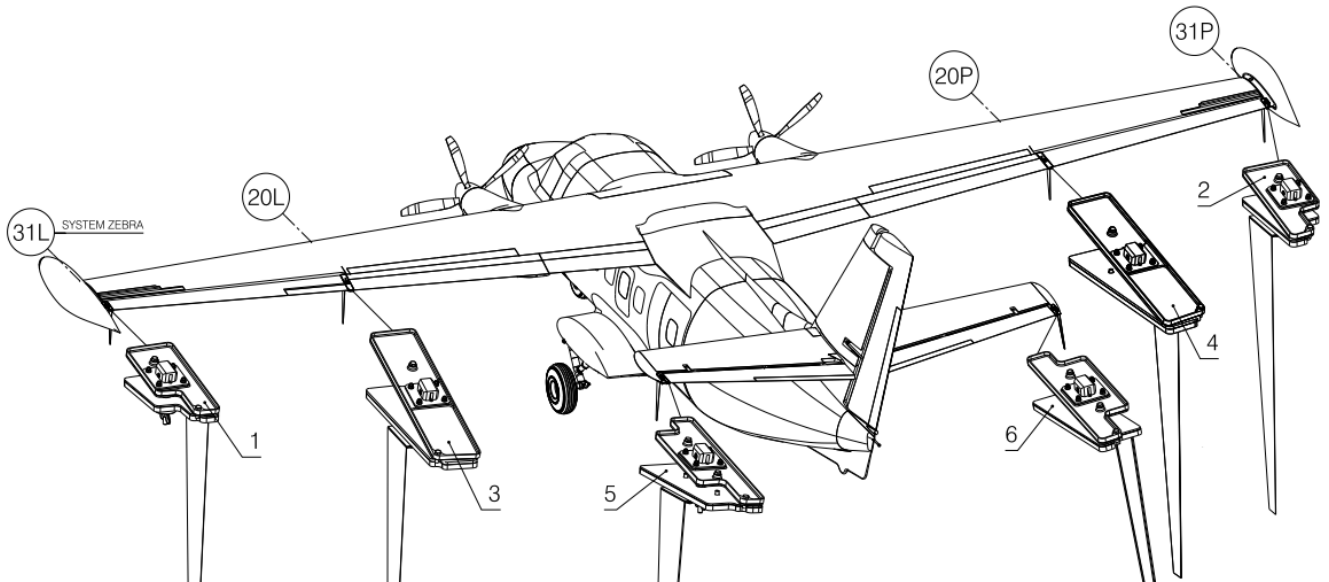

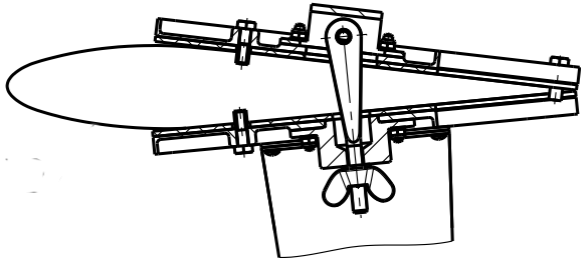
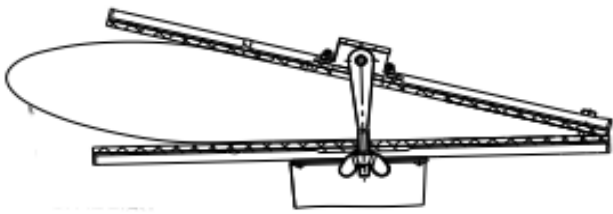
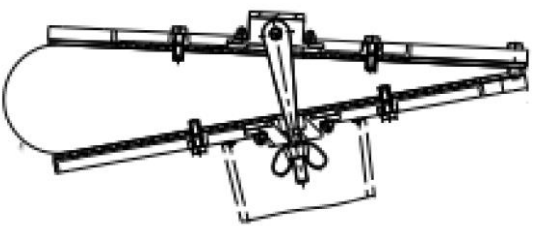
Position	Type / (Drawing No.) Location on Airplane	Section
1	B922120L Aileron outside left	
2	B922120P Aileron outside right	
3	B922145L Aileron inside left	
4	B922145P Aileron inside right	
5	B922100L Elevator outside left	
6	B922100P Elevator outside right	



Ailerons blocking elements installation procedure (4 pcs):

Note: Always park the airplane upwind if possible.

- 1) Prepare stairs (e.g. B097365N) near to the airplane, LH/RH wing
- 2) If the control column was blocked by the B596476N blocking strut (in pilot's cockpit), remove it.
- 3) Set the ailerons to neutral position.
- 4) Set the aileron trim tab to neutral position.

Note: Before using ailerons blocking elements it is necessary to have the ailerons and aileron trim tab in neutral position.

- 5) Before installation, clean the functional surfaces of the airplane that are in contact with the blocking elements (remove snow, ice etc.).
- 6) Put-on the correct type of blocking element on the ailerons (LH/RH, outside/inside), see picture above.
- 7) Install the blocking element and tighten the wing nut on bottom side of the blocking elements.
- 8) Check the correct installation of each blocking element.

Note: The blocking elements must not be in contact with the static dischargers.

Elevator blocking elements installation procedure (2 pcs):

Note: Always park the airplane upwind if possible.

- 1) Prepare stairs (e.g. B097365N) near to the airplane, tail unit
- 2) If the control column was blocked by the B596476N blocking strut (in pilot's cockpit), remove it.
- 3) Set the elevator to neutral position.
- 4) Before installation, clean the functional surfaces of the airplane that are in contact with the blocking elements (remove snow, ice etc.).
- 5) Put-on the correct type of blocking element on the elevator (LH/RH), see picture.
- 6) Install the blocking element and tighten the wing nut on bottom side of the blocking elements.
- 7) Check the correct installation of each blocking elements.

Note: The blocking elements must not be in contact with the static dischargers.

Ailerons and Elevator blocking elements uninstallation procedure (4+2 pcs):

- 1) Prepare stairs (e.g. B097365N) near to the airplane, tail unit, LH/RH wings
- 2) Loose the wing nut on bottom side of the blocking elements.
- 3) Remove blocking elements from the ailerons and elevator (LH/RH).