



MANDATORY BULLETIN

MB No.: L23/048a

Concerning: All L-23 SUPER-BLANÍK gliders up to S/N 039019

Reason: Check of the elevator rocker lever for possible cracks finding

To be carried out not later than: Immediately after the Bulletin receipt

To be carried out by: Disassembly, assembly, painting removal and renewal:
operator
Check by the non-destructive testing -magnetic testing
(NDT MT):
organization approved for tests performance according
to requirements of ASTM E 1444, or MIL-STD-1949, E 709

Costs covered by: Operator
Rocker lever A 730 201 N - in case of change will be delivered
by the manufacturer free of charge

Necessary material to be supplied by: LETECKÉ ZÁVODY a.s.
686 04 Kunovice 1177
Czech Republic
based on the submission of the Record
of cracks presence and the cracked rocker lever

Bulletin becomes effective: On the day of CAA CZ approval

Man-hours: (disassembly, assembly, painting removal and renewal): 2

Sheets: 5

.....
Manufacturer

From the engineering point of view approved by CAA CZ on:
"SAFETY RELATED"

A. WORK PROCEDURE

1. Preparative work

1.1. Rocker lever disassembly

- Disassemble the horizontal tail unit of the glider according to MM (Do-L23-1031.3, Book 2) Chap. 55-10-00, p.401
- Tear off the blind flanges of assembly openings on the up and down side of the elevator at the middle elevator hinge.
- Unlock and disassemble the M5 nut and the bolt of the elevator rotation axis connecting the rocker lever with both sides of the elevator according to MM (Do-L23-1031.3, Book 2) Chap. 55-20-00, p. 2, fig. 1, pos. 2, 4, 5 (the nut M5 firstly - be careful on the shims on the bolt of the rotation axis of the elevator between the rocker lever and the stabilizer hinge).
- Deflect the elevator to the maximum possible deflection up or down and remove the rocker lever.
- In case of problems with the rocker lever removal - remove the bolt of the outer hinge of one half of the elevator (tear off the blind flanges of assembly openings on the up and down side of the elevator and on the tip arch in the rotation axis) see MM (Do-L23-1031.3, Book 2) Chap. 55-20-00 page 2, fig. 1, pos. 9.

1.2. Preparation of the rocker lever for the check

- Follow the recommendation of paint remover manufacturer.
- Protect the openings on both ends of the rod before the penetration of the paint remover (see fig. 1).
- Lay the part on a proper layer, for example on polyethylene foil.
- In the area of paint removal according to fig. 1, by a proper way, for example with a brush, apply on both sides of the rocker lever the paint remover containing chlorinated hydrocarbons (for example P 8201-Ligin).
- Wait till the painting lifts.
- Remove the rest of painting and the paint remover with help of plastic stopper which does not damage the surface of the part.
- If the painting is not removed totally, repeat the procedure.
- Clean the part with help of nitro-solvent (for example C 6000) and cotton rubber.

Warning: During the work keep the work safety and health protection principles - protection of hands and eyes. Perform the work in ventilated areas and according to the manufacturers recommendations.

2. Rocker lever check

Perform the check by the non-destructive testing - magnetic testing (NDT MT). The used method has to comply with requirements of ASTM E 1444 - Standard procedure for testing by magnetic particles, or MIL-STD-1949, E 709. The test parameters depend on the used equipment.

Checked area: Whole circuit of welds connecting the side arms with connecting rod and the welds adjacent area of width of 5 mm.

Criteria of acceptance: Cracks in the checked area of the part are not acceptable.

Warning: In case of cracks finding in the checked area the checked part is not acceptable for next operation. Send this part together with the Record about the test to the manufacturer who will send you a spare part. The Record has to contain the information about the position and size of cracks, S/N of the glider and TSN (flight), and cycles since new.

In case of negative finding (cracks not found) send the information about performed check , S/N of the glider and TSN (flight hours), and cycles since new to the E-mail address safelife@let.cz.

3. Finishing works

- Perform the degreasing of the rocker lever
- Paint the areas of removed painting with the primer on the alkyd basis.
- Paint with the top synthetic coat of relevant shade.
- Perform the assembly of the rocker lever by the opposite procedure to disassembly.
- Stick the blind flanges of assembly openings with one of the contact pastes CHEMOPREN 50, or SCOTCH GRIP EC 1403, coat 3-times by tensioner paint C 1106, or an equivalent on the basis of nictro-coat and with a cover paint of the former color shade.

B. MATERIAL REQUIRED FOR MODIFICATION OF ONE SAILPLANE

Name	P/N	pcs per glider
Rocker lever	A 730 201 N	1

C. ILLUSTRATIONS

Fig. 1: Area of painting removal and checked area of the part.

D. DOCUMENTATION REQUIRED

Maintenance Manual of the L-23 SUPER-BLANIK (Do-L23-1031.3, Book 2)

E. TOOLS REQUIRED

Routine tools, special tools is not required.

F. SPARE PARTS IN OPERATION

Not affected

G. SAILPLANE MASS

Not affected

H. RECORD IN LOGBOOK AFTER BULLETIN IMPLEMENTATION

Performed check / change of the elevator rocker lever according to the Bull. L23/48a.

Date:

Performed by:

(legible signature of verification engineer)

I. ACCOMPANYING DOCUMENTATION

Not affected

OBLAST ODSTRANĚNÍ NÁTĚRU
PAINTING REMOVAL AREA

OTVORY NA OBOU KONCÍCH TRUBKY CHRÁNIT
PŘED ZATEČENÍM ODSTRAŇOVAČE NÁTĚRU
PROTECT OPENINGS ON BOTH ENDS OF THE ROD
AGAINST PENETRATION OF PAINT REMOVER

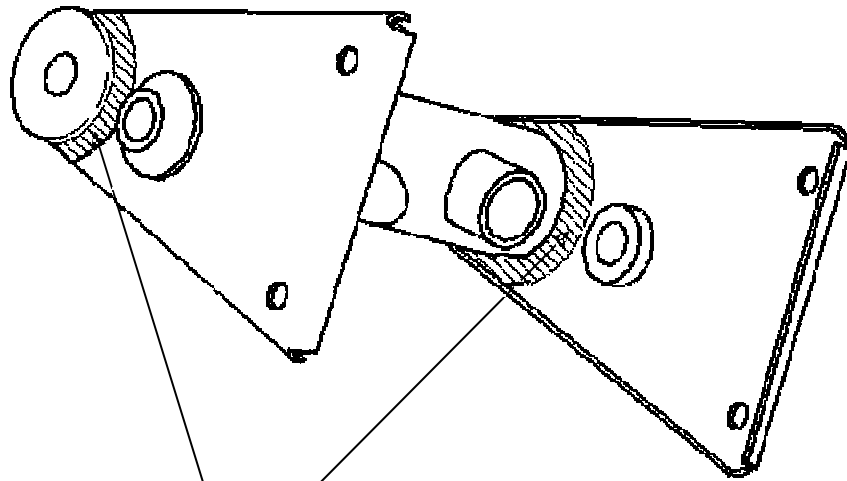
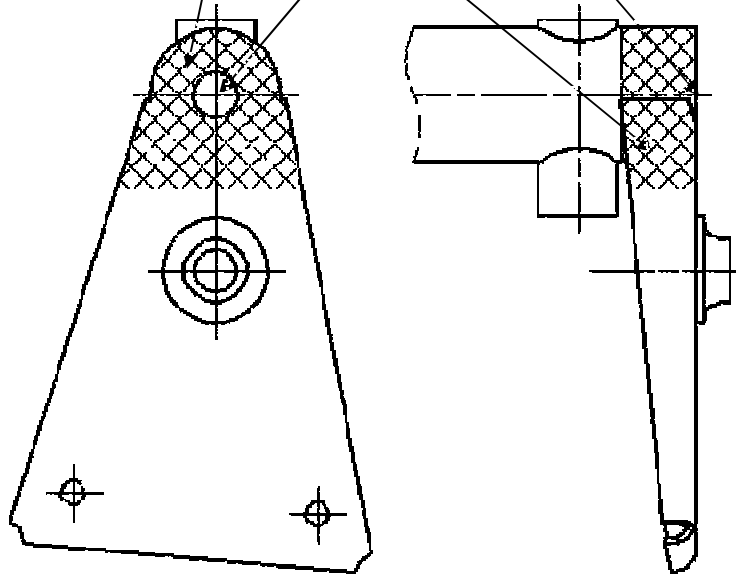

KONTROLOVANÁ OBLAST :
SVARY SPOJUJÍCÍ BOČNICE A TRUBKU A
PŘÍLEHLÁ OBLAST SVARU O ŠÍŘCE 5 mm
CHECKED AREA :
WELDS CONNECTING THE SIDE ARMS
WITH THE ROD AND WELD ADJACENT
AREA OF WIDTH OF 5 mm

Fig. 1